

- Ebony Construction
- Enhanced Single Coil (ESC)
- Two Rows of Polepieces
- High Quality Components

DESCRIPTION

Welcome to the next generation of guitar customization! The Jaén PuPg100 Floating Pickup kit is designed for discerning musicians and guitar makers who demand exceptional tone and unparalleled flexibility.

Checking the Contents of the Box

The kit contains the following components; please check that they are all inside the box:

- A floating humbucking pickup in a case made of ebony wood, designed to fit into the pickguard (the second piece in the kit) with precision. The dimensions are as follows:

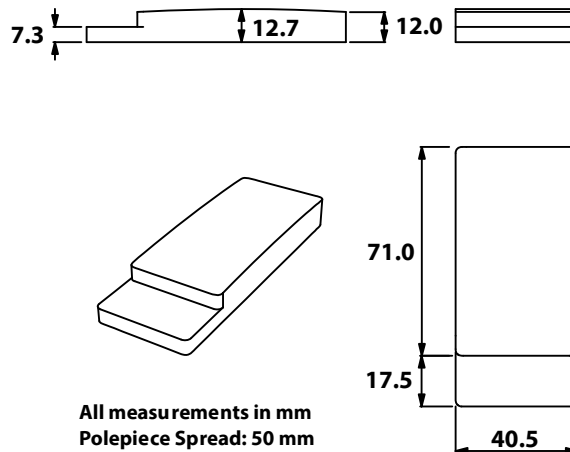

Figure 1 - Pickup Dimensions (mm)

The pickup has a short cable, not represented in the drawing, that runs horizontally as shown here:



Figure 2 - The back of the pickup, showing the cable. It extends around 15 cm.

The polepieces can be chrome, gold (titanium nitride) or black, depending on what you specified with your order. In normal use, the threads won't protrude from the back of the pickup case. There is also a bag with a few shorter polepieces and an Allen wrench (2.5 mm).

- A pickguard assembly, with its main body made of ebony wood:

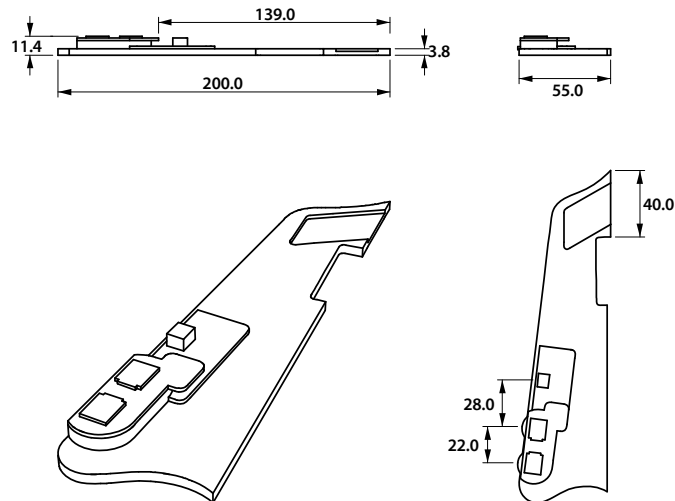

Figure 3 - Pickguard dimensions (mm)

It comes with two printed circuit boards already installed that house the pots, the ESC switch and other components. The aluminum mounting bracket, also in the kit, is not glued yet. There are also some wood screws that you can use to join the drilled bracket to the neck of the guitar.

Highlights

This pickup/pickguard kit showcases a distinctive and unconventional design, where every detail is intentionally crafted with a purpose that goes far beyond visual appeal:

A wooden pickup in a wooden pickguard in a wooden guitar

The case of the pickup and the pickguard body have been carved from a single solid piece of ebony wood, then hand sanded and polished. Polished ebony is shiny and beautiful even if, like here, it doesn't have any wax or finish (you should apply some after you have finished the installation, as explained later).

Saving space is important

I have worked hard to make both the pickup and pickguard slim. The pickup coils don't have thick plastic spools; instead, they are separated from the outside world by a thin paper. This way, if you need a higher output pickup, it can be done: there is space inside the case for more copper (and I do custom work). The potentiometers are of a special type that combines quality, long life and small size. The switch is small but surprisingly robust.

Floating pickups sound thin to your ears? Try this one.

Through the years I have met a few players who, tired of trying thin-sounding floating pickups, were asking for advice to install a full-size conventional unit. Consistently, they were willing to *murder* (I guess there is not a much better word) the top of their archtop guitar. My advice then went along what Oscar Wilde said once: one should never do anything that one cannot talk about after dinner. Now I also mention that this floating pickup, unlike most of its kind, has a high inductance: around 4.6H in Humbucker mode and 4.2H in Enhanced Single Coil mode (ESC, see below). Also, the two rows of pole pieces are spaced far enough apart to pick up the string differently, giving that subtle complex depth so typical of humbuckers. Say goodbye to thin, fragile tone.

Versatility is also for archtops: ESC, tone cap switching and treble bleed.

A humbucker that can be switched to single coil is great, but most times it doesn't work as well as we expect. The ESC (Enhanced Single Coil) feature is activated by a switch in the pickguard assembly that permits to select either a Humbucker or a ESC. When in Humbucker mode (toggle towards the neck), you'll have a full tone, almost free of hum. In the ESC position (toggle towards the tailpiece), the coil farther from the neck will be cut. The tone will be more clear and bright, although more prone to being affected by electromagnetic interference. Single coil pickups obtained by canceling one of the coils of a humbucker (as done here) are usually set aside, as they tend to be much weaker than real single coils. Nonetheless, the ESC mode also adds more turns on top of the active coil, giving you the tone and punch that you expect from a *real* single coil. Even more, the tone capacitor will be different in both modes; the kit comes with 22nF for HB and 47nF for ESC.

Finally, if you want, you can add treble bleed components to improve the perception of the guitar tone at low volume (there is room for them in one of the PCBs, but none have been installed).

More supported string types means even more versatility.

The polepieces are in a double row configuration. They can be adjusted with an Allen wrench (included), which allows to adapt the output of each individual string for each individual coil. The two rows are useful for equalizing bronze strings, which you can use now: the output of wound strings differ so much from the output of plain strings that single-row pickups can't compensate completely, but two rows can do it!

Never use a shitty component for a high-end guitar. Or for any guitar.

The components are all high quality. The potentiometers in the kit have an average lifespan of 100,000 rotations, which puts them on par with the full-size CTSs. Furthermore, their resistive track is a conductive polymer, much less noisy than the carbon of all major brands of guitar potentiometers. Compare these to the usual pocket-radio pots used extensively for below-the-pickguard in all kinds of archtops, cheap and expensive, which are usually rated at about 10.000 rotations. Then you'll agree on the title of this paragraph.

INSTALLATION

Important: Only a reputable technician should install this kit

Previous checks (please read this section thoroughly before you start the installation):

- The guitar must have at least a space of 14 mm between the top of the fretboard (excluding the frets) and the guitar's top:

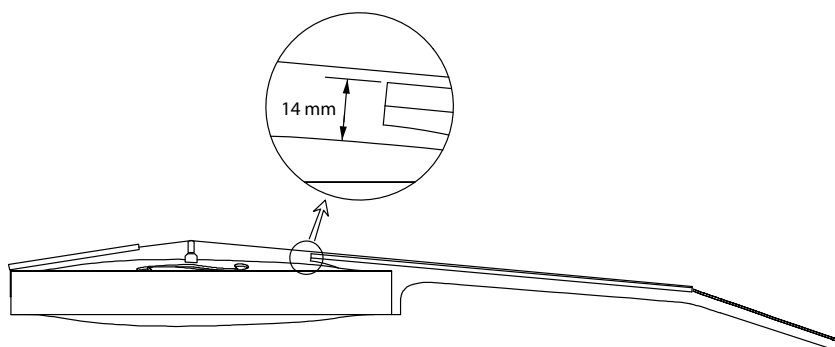

Figure 4 - If your guitar doesn't pass this check, don't buy the kit

- The pickup has 50 mm between the polepieces of the first and sixth strings. So, the guitar strings should have a similar spread in this area. Between 48 and 52 mm would be fine.

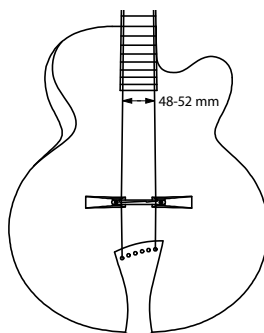

Figure 5 - Most guitars will pass this check

- It is possible to use the kit for guitars that have a width between 53 and 65 mm at the neck end.

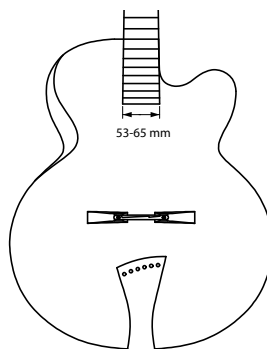

Figure 6 - Few guitars won't pass this check

The lower limit of 53 mm is possible because the pickguard has an extra 2 mm of wood in the area where it joins the side of the neck:

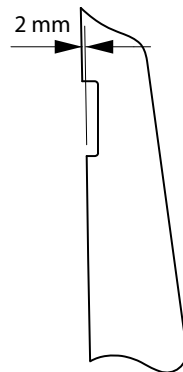

Figure 7 - The pickup has excess wood where shown

- The fretboard taper for which this kit was made measures approximately 10 mm from the nut to the 12th fret (for all common scales around 25 inches). This means that if the nut is 43 mm wide, then the width at the 12th fret will be about 53 mm, 10 mm more. The angle between the pickup and the pickguard is exactly half the angle between the two sides of the fingerboard, which is the taper, so you see that the kit design is tied to this characteristic. If your instrument doesn't taper like that, you'll need to modify *something*.

Except when the adjustment is small, I don't recommend that you modify the angle at the bracket area, as in Figure 8a, because the bracket is made to fit very well in its cavity... but it won't after the modification. Usually the easiest way is to modify the pickup pocket in the pickguard, Figure 8b, to remake the angle between the pickup and the pickguard, *keeping the angle at the bracket area untouched*. This will also keep the pickguard edge more or less parallel to the first string after the adjustment.

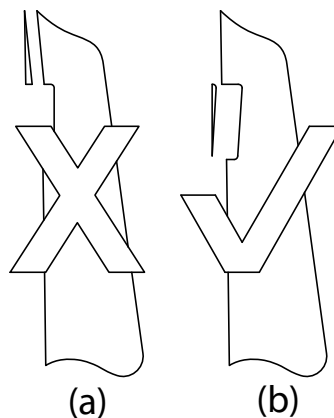

Figure 8 - Two ways to modify a pickguard, one better than the other

Few guitars, if any, will have such an unusual neck taper that the kit can't be fitted.

- Some guitars have an irregular, uneven neck profile, or an undesirable angle limited to the pickguard bracket area. This will cause the pickguard to sit at an incorrect angle, and the pickup will likely be as well.

Normally, this isn't a major problem and can be resolved by shimming the bracket, removing wood from the pickup tab or pickup pocket, etc.

- Another problem is that the pickguard section ahead of the pickup might be too large (Figure 9), causing the cutaway to be *behind* it. If this happens, the player's hand will be restricted, not by the cutaway itself, but by the pickguard, which is undesirable. Some wood can be removed from the forward end of the pickguard, but it's limited to around three millimeters before you start to cut the bracket cavity. Cases that fall outside these adjustments would be quite marginal with rounded cutaways; In any case, there could be problems with some guitars that have pointed cutaways, such as the guitar in Figure 9, which seems particularly unsuitable for this kit.

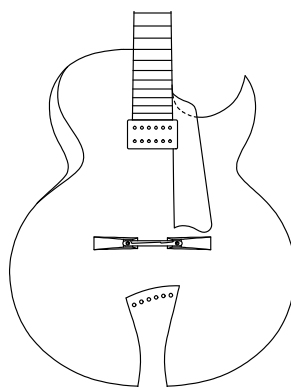

Figure 9 - Some pointed cutaways don't get along very well with the pickguard

- An additional requirement is that space is needed for the pots so that, if the pickguard follows more or less the lay of the strings, they don't collide with the top. You can see from the dimensions diagram that the total thickness there is about 11.4 mm. Normally there will be plenty of room, much more than needed, on most archtop guitars (see Figure 10).

It could also happen that short scales combined with many frets could pose problems with the overall length of the pickguard, which might interfere with the bridge or other structures. This will be uncommon also but, if in doubt, please check the dimensions in Figure 3.

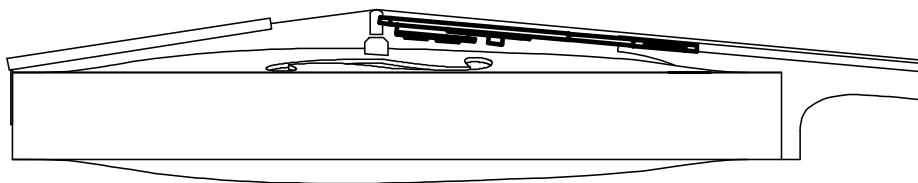

Figure 10 - The pots below the pickguard are not a big problem in most cases

Installation Guidelines (please read this section thoroughly before you start the installation):

1. You'll see some pickguards that follow more or less the lay of the strings, as in Figure 10. Other times, they fall a little towards the bridge. Also, sometimes the pickguard surface is in the same plane as the

pickup top side (Figure 11a); other times, it falls a little, forming an angle with it (Figure 11b). You'll see examples of all kinds in all ranges of instruments.

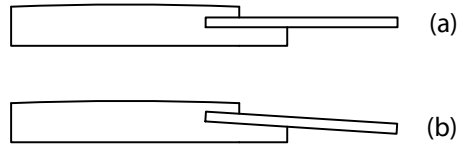

Figure 11 - Different pickguard tilting angles

- The pickup, viewed from the tailpiece (Figure 12, same view as Figure 11), should be horizontal. Its top should be around 1 mm below the surface of the fretboard at the center:

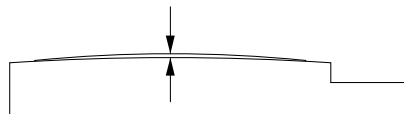

Figure 12 - The surfaces of the pickup and the fretboard

To achieve this, it will probably be necessary to either adjust the angle/height of the pickguard or file/sand/chisel the pickup tab. In the latter case, please consider that there is a limit: don't remove more than 2 mm from the area near the corner of the tab, and perhaps 3 mm on the rest. Be very careful if you put the pickup in a machinist vice: excessive pressure will break it!

- When you glue the pickup to the pickguard, please follow these recommendations :
 - Use Titebond or some other wood glue.
 - Don't use a lot of glue, and even less at the corner of the pickup tab: **excess glue tends to travel through the thin line between the two pieces.** It will appear at the top, and may become very visible.
 - Use a couple of plastic spring clamps to press the pieces together, but **don't leave them alone immediately**, as they tend to slip slowly.
- The pickup will be connected to the four pads on the top side of the Switch board, following the colors for the wires indicated in Figure 13:

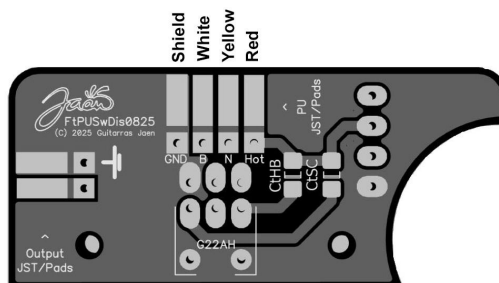

Figure 13 - Switch PCB

5. The output cable, which must be shielded, will be connected to the two pads on the left side of the Switch board (Figure 13). It's my error that there is no printed information of which terminal is ground, but I have painted a symbol on the board to indicate it, that also appears on Figure 13.
6. There are two capacitors (Figure 13) on the Switch board, labeled CtHB and CtSC which are the tone capacitors for the Humbucker and for the ESC (Enhanced Single Coil) modes. They are 22nF and 47nF respectively. Feel free to substitute them for some other; they must be surface mount (SMD), size 1206, NPO ceramic.
7. There are two empty places for components on the Pots board (Figure 14), labeled Ctb and Rtb. They are designed for holding Treble Bleed components, usually a resistor and a capacitor. They must be both surface mount (SMD), size 1206. The resistor, Rtb, should be the metal film type, usually 150K. The capacitor, Ctb, NPO ceramic, usually 1000 pF. Treble Bleed circuits prevent the guitar from losing high frequencies when the volume knob is rolled down.

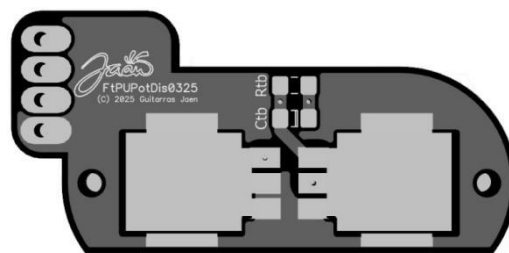

Figure 13 - Pot PCB

8. The aluminum bracket will have to be filed, cut and drilled until it fits your instrument. Then it will have to be glued to the pickguard. Epoxy may be adequate, but most epoxies need some special treatments on the surface of the aluminum that are not easily available; otherwise the bond will not be reliable. The best adhesive for aluminum, in my experience, is two-component MMA (methyl Methacrylate), which has become quite popular lately. It forms a very resistant bond on aluminum with little preparation (although sanding and cleaning with acetone is always recommended). For attaching the bracket to the guitar, use the screws supplied.

CONTACT

Guitarras Jaén (Fernando Jaén) - Carretera de Pozorrubio, 92 - 16410 Horcajo de Santiago - Spain
Phone: +34 620791064
www.guitarrasjaen.com
jaen@guitarrasjaen.com